

MODELS:

SRW12US / SRW12USG

SmartRack® Wall-Mount Rack Enclosure Cabinets



12 Rack Units



200 lb.
Load Rating



Sturdy Steel
Construction



Locking Doors
& Side Panels



Plexiglas®
Front Door
(SRW12USG
only)



Standard
EIA
310-E



Convenient
Cable Access



Adjustable
Mounting Rails



Hinged Wall
Bracket



Ventilated for
Ample Airflow



Reversible
Cabinet



Square Hole
Mounting

- A** Front Door
(Lockable/Removable/Reversible.
SRW12US door is perforated;
SRW12USG door has a Plexiglas® insert.)
- B** Adjustable Mounting Rails (4)
- C** Side Panels (2)
(Lockable/Removable)
- D** Hinged Wall Bracket
(Lockable/Reversible. Allows the cabinet
to swing away from the wall for convenient
rear access to equipment and cabling.)
- E** Cable Access Port Covers (2)
(Removable)
- F** Ventilation Fan Ports (4)
(Support optional SRFANWM fan kit.)
- G** Keys (2)

Also Includes: Owner's manual, mounting
plate screws (3), cabinet ground screw, pre-
installed front door ground wire and rackmount
equipment mounting hardware (12 cage nuts,
12 mounting screws, 12 nylon cup washers).

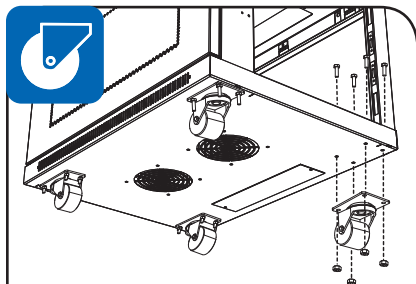

Floor-Standing Installation: Optional SRCASTER
kit adapts cabinet to roll under desks, tables or
counters. (Kit includes 4 casters.)

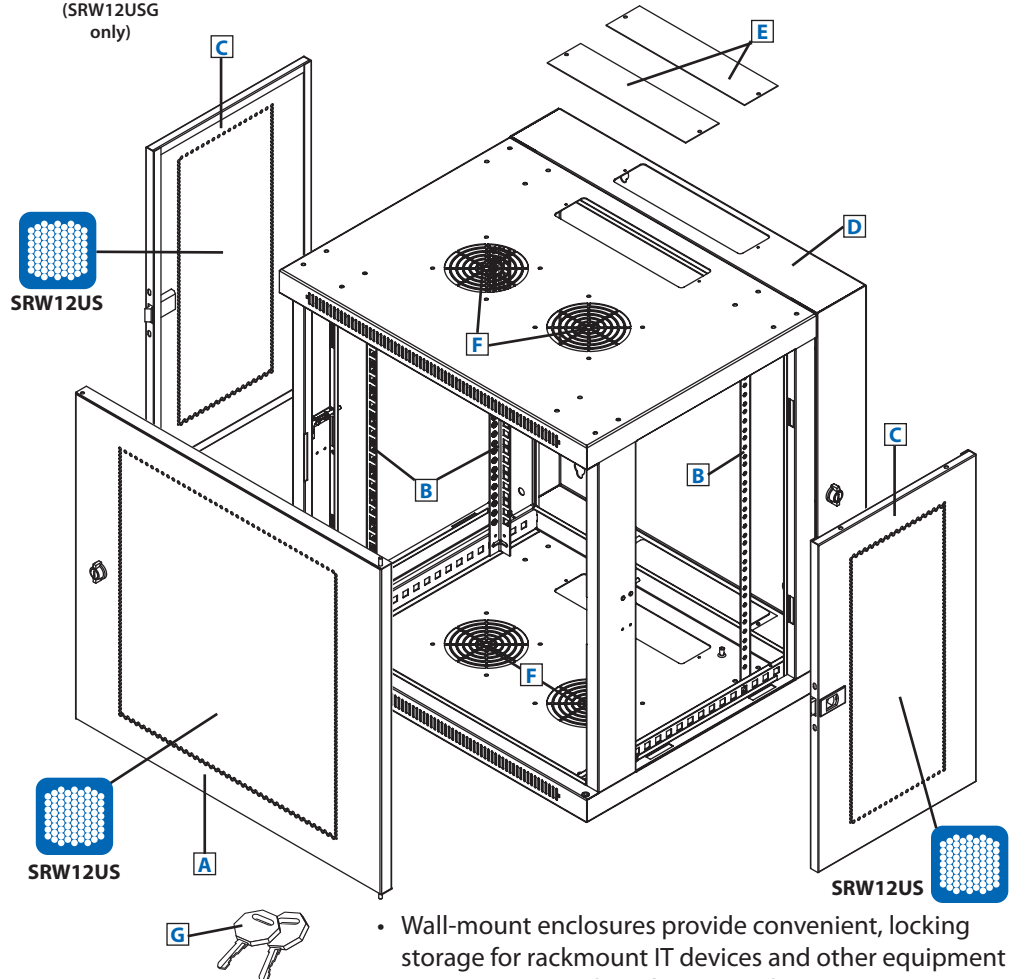

- Wall-mount enclosures provide convenient, locking storage for rackmount IT devices and other equipment that should be off the floor, out of the way and secure
- The cabinet is fully reversible, allowing installers to change door hinges from left to right by simply rotating the unit 180 degrees before mounting
- Hinged wall bracket allows cabinet to swing away from the wall for convenient access to equipment and cabling

SEE NEXT PAGE FOR DETAILED UNIT MEASUREMENTS



1111 W. 35th Street
Chicago, IL 60609 USA
773.869.1234
www.tripplite.com

Specifications

Models	SRW12US / SRW12USG
Rack Spaces	12U
Equipment Mounting Depth	Up to 20.5 in. (520.7 mm)
Load Rating*	200 lb. (90.7 kg)
Unit Dimensions (H x W x D)	25.08 x 24.53 x 21.57 in. (637 x 623.07 x 548 mm)
Shipping Dimensions (H x W x D)	27.95 x 26.38 x 24.41 in. (710 x 670 x 620 mm)
Unit Weight	60 lb. (27.21 kg)
Shipping Weight	64 lb. (28.8 kg) / 70 lb. (31.5 kg)
Regulatory Compliance	Meets EIA-310-D, IEC 60297-3-100, NOM, RoHS and PCI-DSS standards; IP20 Protection Rating

* The load rating includes the combined weight of the unit and installed equipment. The unit must be mounted to a stable surface with user-supplied anchors capable of bearing the full load. Tripp Lite has a policy of continuous improvement. Specifications are subject to change without notice.



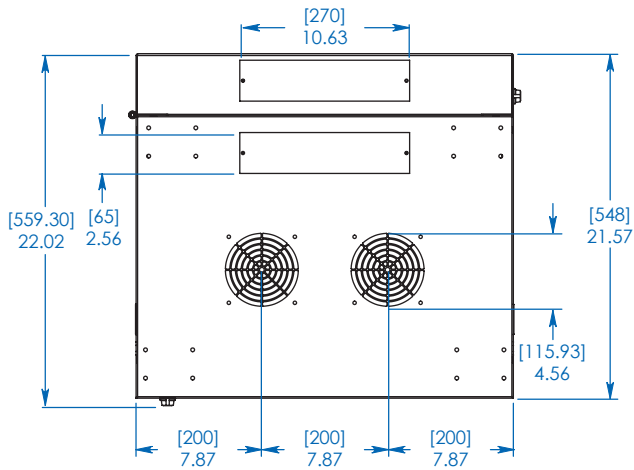

TOP/BOTTOM VIEW

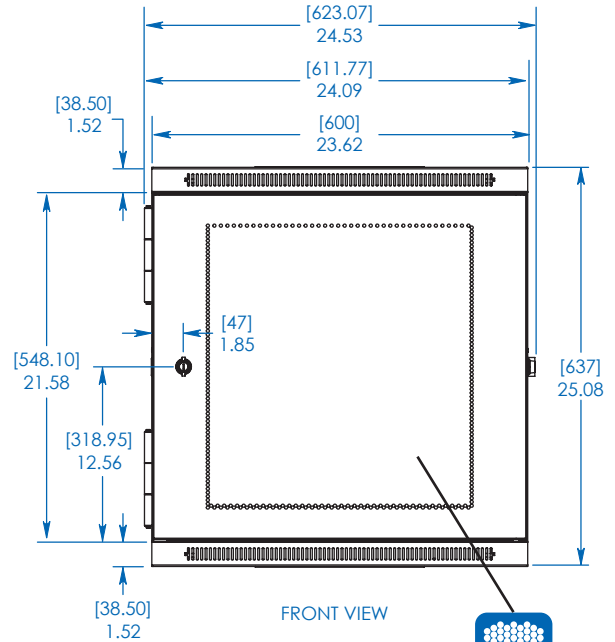

FRONT VIEW



SRW12US

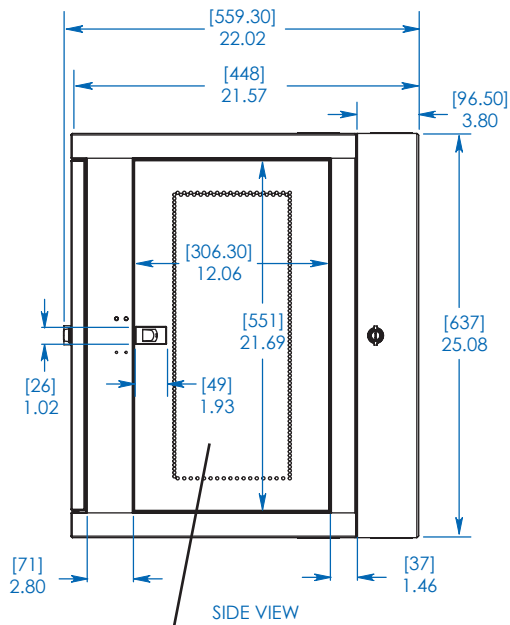

SIDE VIEW



SRW12US

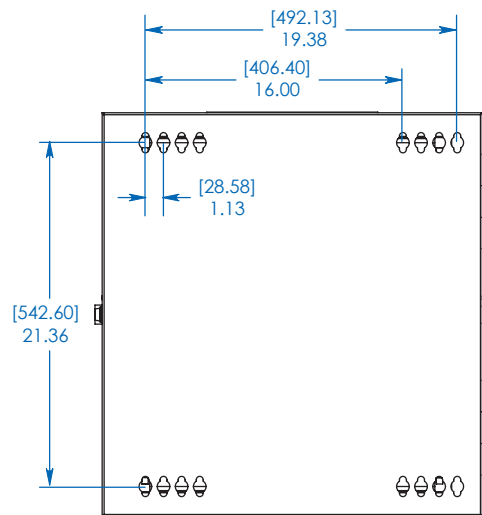

REAR VIEW

Dimensions: [mm] INCHES

Tripp Lite has a policy of continuous improvement. Specifications are subject to change without notice.

MODELS:
SRW12US / SRW12USG



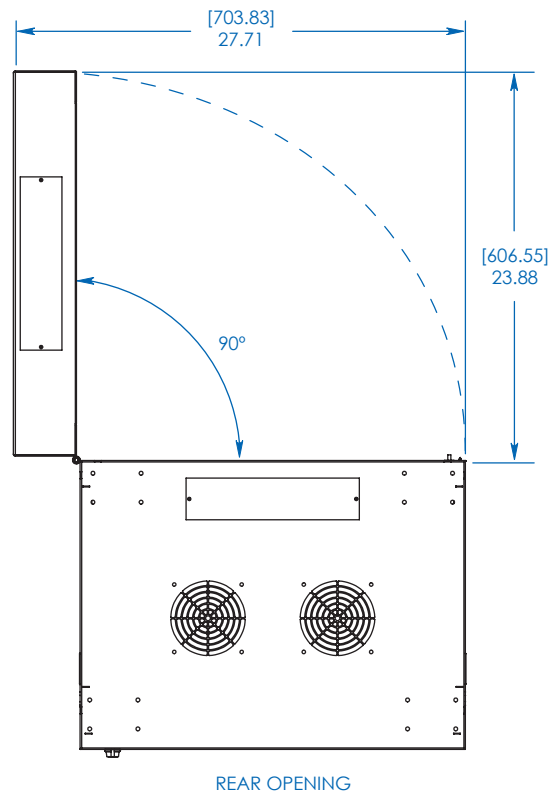
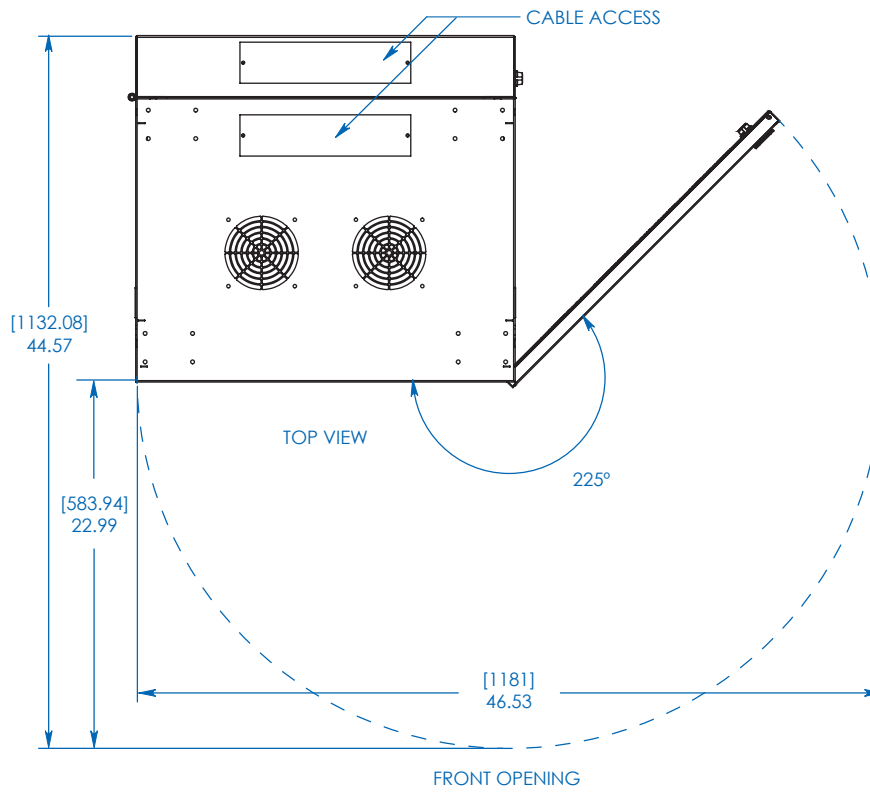

MODELS:
SRW12US / SRW12USG



1111 W. 35th Street
 Chicago, IL 60609 USA
 773.869.1234

www.tripplite.com

Dimensions: [mm] INCHES

Tripp Lite has a policy of continuous improvement. Specifications are subject to change without notice.